



## SAT IF distribution technologies

Multiswitches and single cable multiswitches for 1, 2, 3 or 4 SAT positions  
optical distribution

***Wide Band***  
approved - 2.4 GHz

- 
- A close-up view of a satellite IF distribution unit connector, showing the internal components and the connector housing.
- ✓ Cascadable
  - ✓ Wide product range
  - ✓ Suitable for multimedia
  - ✓ Single cable acc. to EN 50607, compatible with EN 50494

# Always the right solution



## Why should a multiswitch system be used?

A multiswitch system offers the end user total flexibility and a maximum choice of TV programs (SDTV / HDTV / 4K-UHD). Multiswitches enable many satellite set-top box users to share a single satellite antenna. Multiswitches can also help to avoid both: many dishes on a building and a lot of unstructured cabling.

## When will you use single cable multiswitches?

In old buildings, in which a star-shaped installation is not possible, single cable multiswitches will be used. Thus, existing tree-shaped structure can be used for SAT-IF distribution. A single cable multiswitch provides the received programs divided into several user bands. There are a maximum of 32 user bands available at one output. The connected receiving devices must be compatible acc. to EN50607 or EN50494 (8 user bands).

## What's the purpose of a cascadable system?

The cascadable system is suited for big installations with a large number of subscribers. If the subscribers live on different floors it inevitably causes different cable lengths. As a result, the cable lengths to the subscribers can be kept as short as possible. This system is very flexible, which allows to extend it in case more subscribers need to be added.

## Optical distribution

The optical transmission technology is used when it comes to transmitting signals over long distances. This kind of distribution is virtually lossless as well as free from noise and distortion. Only one optical fiber cable per satellite position is needed.

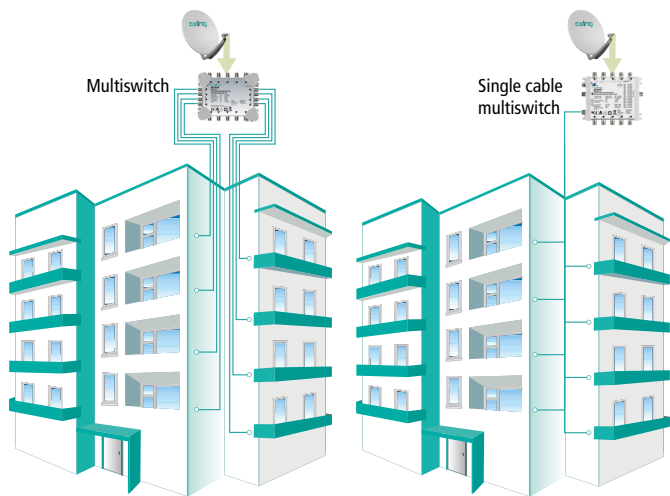

- ✓ User-friendly
- ✓ Great variety of programs
- ✓ Television in high quality

- ✓ Only one satellite antenna for a large number of subscribers
- ✓ Available for 1, 2, 3 or 4 individual satellite positions with up to 16 individual satellite polarities



- ✓ SDTV/HDTV/4K-UHD digital signal quality at all antenna wall outlets
- ✓ High screening according to Class A

## MG 1-00 – DVB-TV Meter Easy to use due to intuitive operationg



The measuring device MG 1-00 supports the installation and maintenance of coaxial reception systems. It is used for the qualitative measurement of digital terrestrial television channels, satellite systems or cable networks.

# premium-line multiswitches for the highest demands

Highest performance with many subscribers and long cable distances – no problem.

With the complete product portfolio consisting of **premium-line** multiswitches, cascaded multiswitches, amplifiers, splitters, taps and last but not least suiting earthing angles an optimum installation solution can be guaranteed.

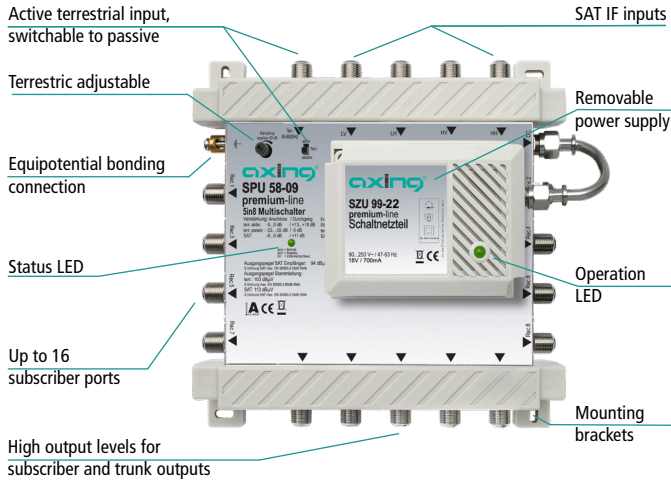

- ✓ Great variety of programs
- ✓ Television with high quality
- ✓ SDTV/HDTV/4K-UHD

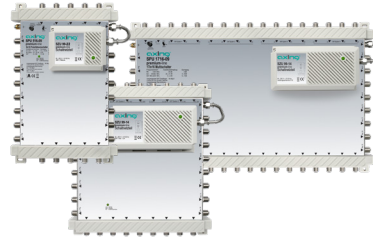

- ✓ Available for 1, 2, or 4 individual satellite positions
- ✓ For 4, 6, 8, 10, 16 or 18 subscribers

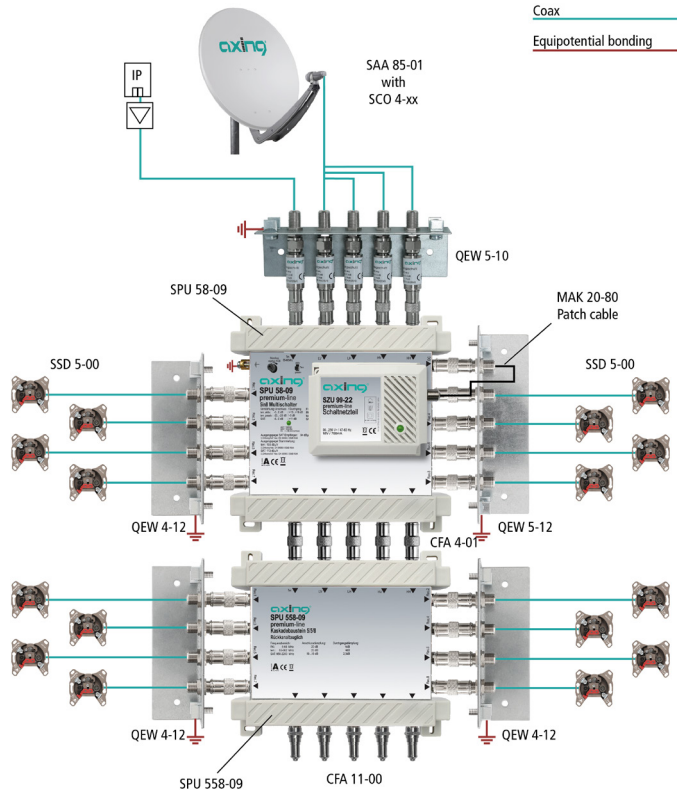

# basic-line multiswitches – the alternative



## SPU xxx-06: basic-line multiswitches – cascadable

AXING's **basic-line** multiswitches are an inexpensive alternative for SAT-IF distribution. The several devices can be used as stand-alone-versions or in a cascaded system.

Multiswitches for 1, 2, 3, or 4 satellite positions with terrestrial input are available. The devices are offered with 8, 12, 16, 24 or 32 subscriber outputs.

Furthermore new head amplifiers SVS xxx-06 can be used before the inputs or within a cascaded system.

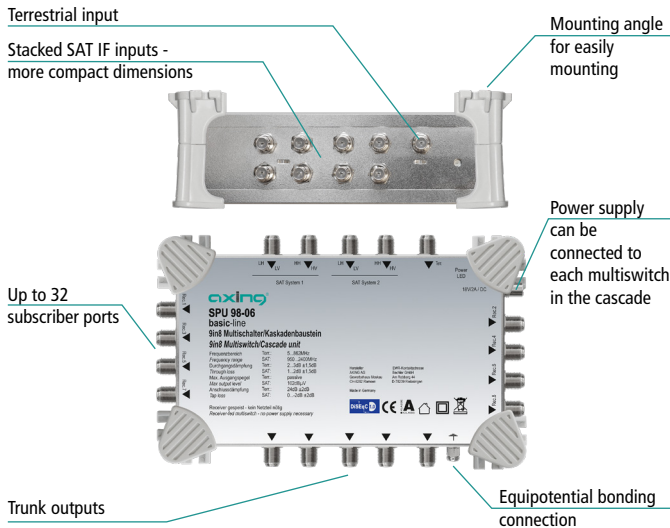

## Complete multiswitch packages

The multiswitch packages are completely pre-assembled on a perforated mounting plate. QEW earthing brackets are installed at the inputs and subscriber connections, the inputs are provided with surge protection. The trunk outputs are terminated with DC-decoupled terminating resistors. Equipotential bonding within the package is provided, the perforated mounting plate only needs to be grounded on site.

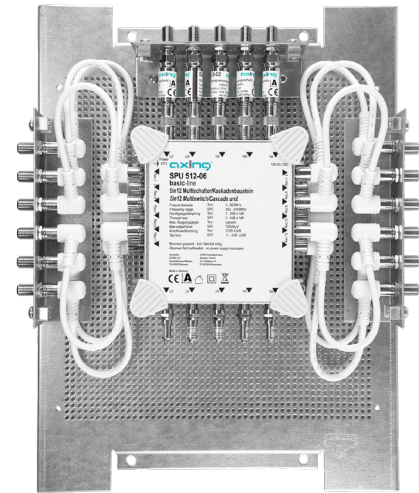

Multi-switch packages with one satellite position and 8, 12 or 16 subscriber outputs are available by default. Individual multiswitch complete packages can be manufactured on request.

## SPU xxx-05: basic-line multiswitches – stand-alone



### Power supply:

- ✓ SPU 5xx-06 can be supplied by multiswitch
- ✓ SPU 9xx-06, 13xx-06 and 17xx-06 can be supplied by SZU 99-06 power supply units. They can be connected to the multiswitch or headamplifier
- ✓ Headamplifiers can be used as input or trunk amplifiers between cascaded multiswitches
- ✓ Remote power supply within the cascadable system over the SAT IF lines due to a switchable DC pass
- ✓ SPU 5xx-05 with integrated power supply

# premium-line single cable multiswitches

## Continue using installed tree structures

In old or new buildings, where a star-shaped installation is not possible, single-cable multiswitches are used. Already installed tree structures can continue to be used.



By staggering the premium-line single-cable multiswitch series, single-cable systems can be set up for small to large residential properties. The individual devices can be used both as stand-alone units and as cascade modules.

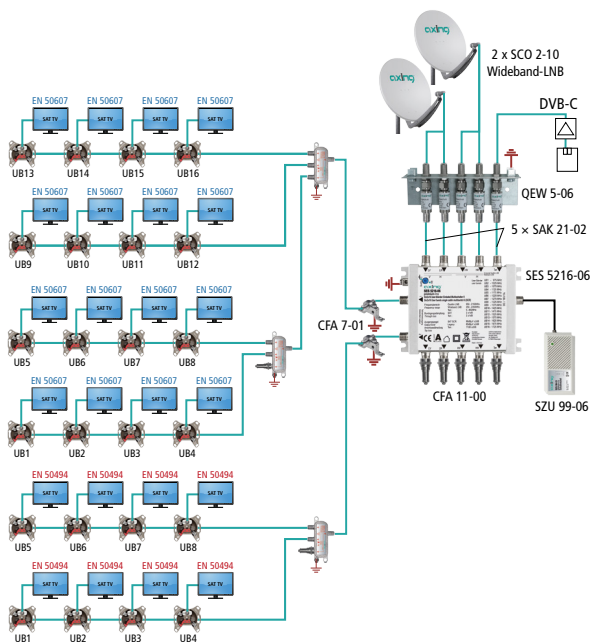

All types are wideband capable. This means that either 2 or 4 SAT positions can be received with wideband LNBs.

## Benefits at a glance:

- ✓ Use of existing coaxial cable structure, no dust, no dirt
- ✓ For small to large buildings
- ✓ Wideband technology
- ✓ Existing lines can be assigned several user bands for single-cable receivers (e.g. for twin receivers)

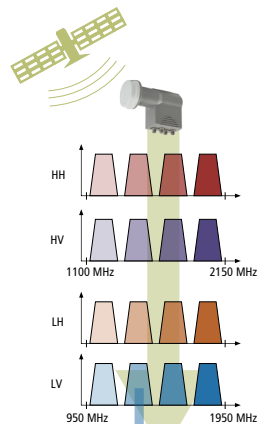

## Single cable principle

The receiver uses DiSEqC commands (1) to transmit the level and transponder of the desired programme to the multiswitch. The transponder is then converted to the user band of the receiver (2).

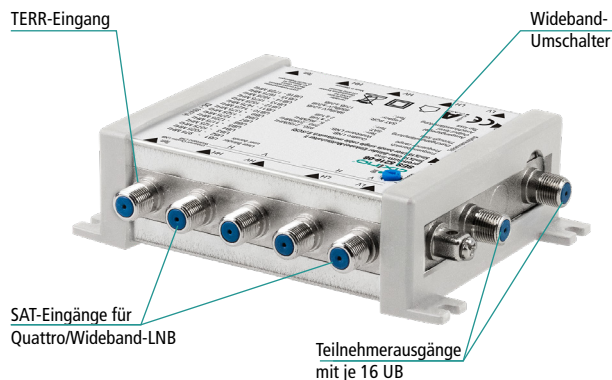
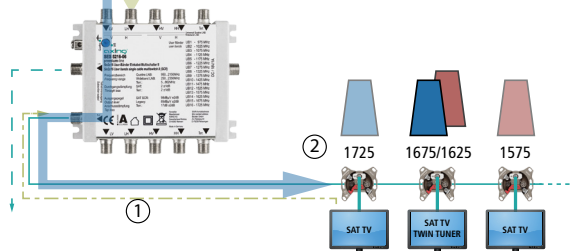

## Wideband technology

When using a wideband LNB the complete frequency range of one satellite can be transported on two cables within a range from 300 MHz to 2350 MHz. This means only two coaxial cables are needed for one satellite position, which means that a further satellite position can be transmitted.

This technology can only be used with a single cable multiswitch.

The connected receivers must be compatible with EN 50607 or EN 50494 (8 user bands).

# Optical distribution



## Signals over long distances

For optical transmission of satellite signals and CATV channels, a transmitter, several receivers and a wide range of accessories of distributors, cables and attenuators are used.

The RF signals are converted into optical signals. These are distributed from the output of the transmitter via distributors and optical cables over long distances to optical receivers without noise or distortion. The receivers convert the optical signals back into satellite signals and the CATV channels.

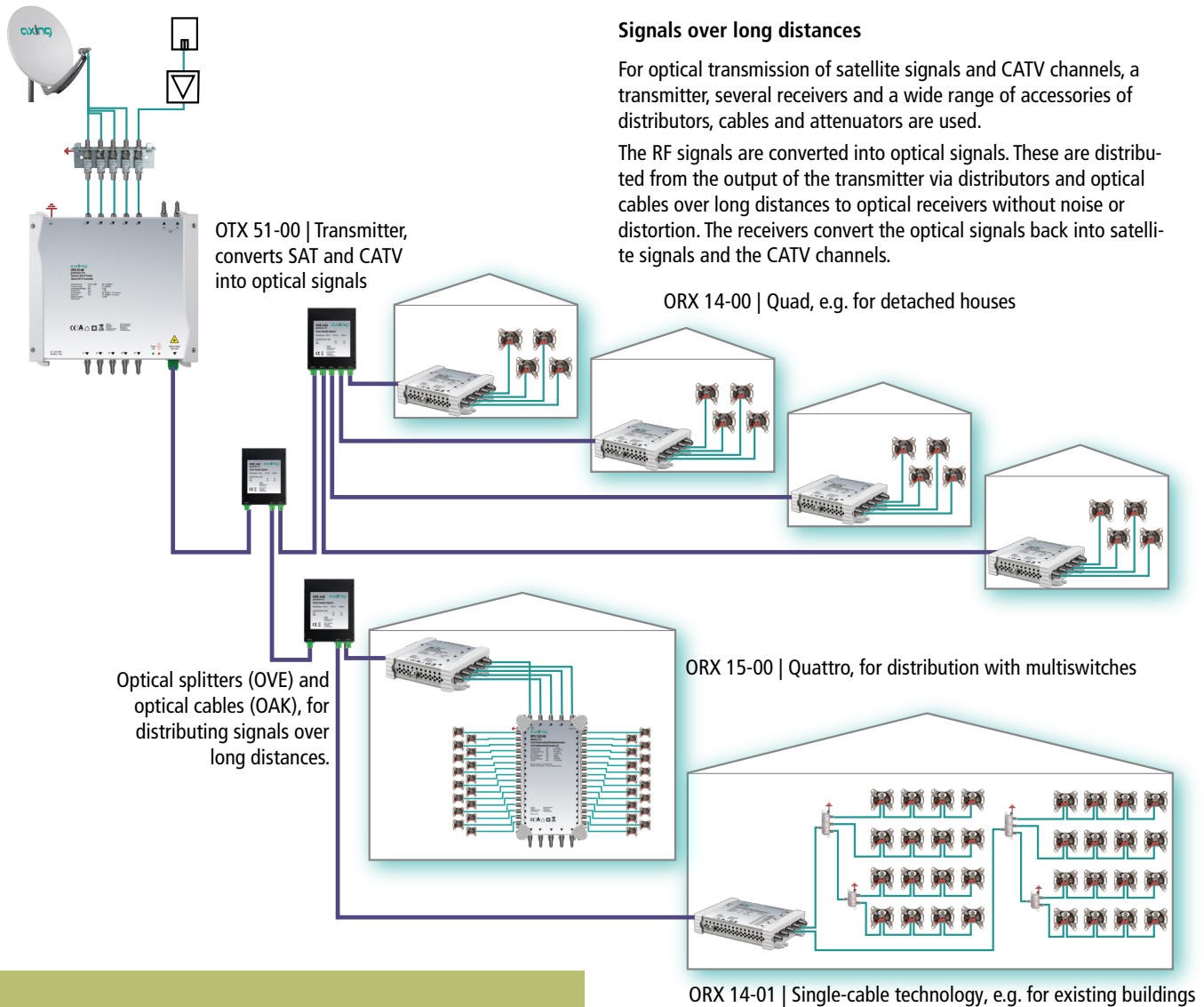

## Benefits at a glance:

- ✓ Almost loss-free as well as noise-, distortion- and interference-free transmission
- ✓ Transmission over long distances, to many buildings and subscribers
- ✓ Easy installation in existing empty conduits
- ✓ Only one fibre optic cable per satellite position



In addition to the optical transmitters and receivers, optical distributors, cables and accessories are available.

## Why AXING in particular?

We Swiss don't waste words. But what we do, we do thoroughly. Which is why AXING products are always state of the art. The compact design and easy installation are equally impressive.

What is more, with AXING you have a partner at your side offering you all the services you need as a one-stop provider – from planning via preparation through to delivery and operation. Contact us now; we would be pleased to advise you on site and make you a detailed offer.

### Our AXING commitment:

- ✓ Very easy handling and installation of all AXING products
- ✓ Short-term and reliable delivery capability
- ✓ Consistently high quality
- ✓ Highly modern technology – state of the art
- ✓ Great flexibility due to wide variety of products
- ✓ Optimum support via competent planning and installation service
- ✓ Technical service / after sales



### AXING AG

Gewerbehäus Moskau

Phone +41 52 - 742 83 00

Fax +41 52 - 742 83 19

2021-06-14 – Technical improvements, changes in design, printing- and other errors reserved.

 8262 Ramsen

[info@axing.com](mailto:info@axing.com)

[www.axing.com](http://www.axing.com)